

Installation Guide

Model 267 and 267MR
Differential Pressure Transducers

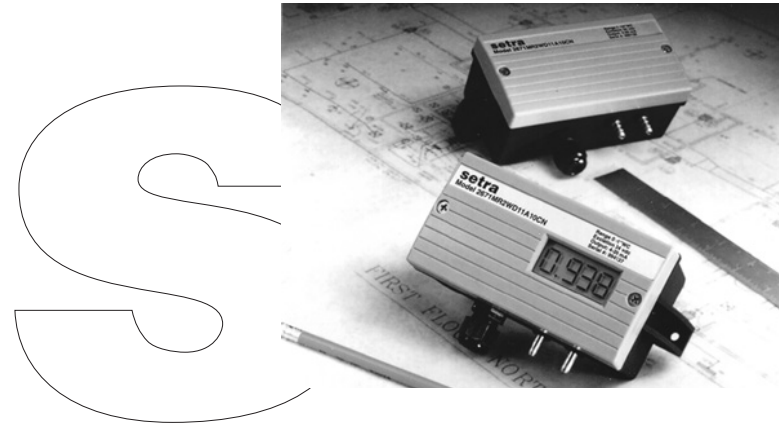

Setra offers a complete line of HVAC Products

Model 264	For Static Duct and Flow Measurement
Model 265	Smaller Size 10 PSI Overpressure
Model 230	Wet/Wet Differential Pressure Measurement
Model 209	Rugged Low Cost Gauge Pressure Measurement from 0-5 to 0-1000 PSIG

10.0 MODEL 267 DESICCANT COVER

The desiccant can be easily regenerated or replaced. When the desiccant has absorbed all the moisture it can hold, the user is alerted through the clearly visible desiccant status window, which changes from blue (dry) to pink (saturated). (Note: Life expectancy of the desiccant is approximately six months)

10.1 Regenerate the Desiccant

The desiccant can be regenerated by removing the cover from the base and baking it in a conventional oven at 200°F for 3-4 hours or until it returns to its dry status (blue).

10.2 Replacing the Desiccating Cover

To ensure the uninterrupted system operation, replacement covers with desiccant are available. Contact your local representative or Setra Systems' customer service department at (800) 257-3872 to order.

8.0 RETURNING PRODUCTS FOR REPAIR

Please contact a Setra application engineer (800-257-3872, 978-263-1400) before returning unit for repair to review information relative to your application. Many times only minor field adjustments may be necessary. When returning a product to Setra, the material should be carefully packaged and shipped prepaid to:

Setra Systems, Inc.
159 Swanson Road
Boxborough, MA 01719-1304
Attn: Repair Department

To assure prompt handling, please supply the following information and include it inside the package or returned material:

1. Name and phone number of person to contact.
2. Shipping and billing instructions.
3. Full description of the malfunction.
4. Identify any hazardous material used with product.

Notes: Please remove any pressure fittings and plumbing that you have installed and enclose any required mating electrical connectors and wiring diagrams.

Allow approximately 3 weeks after receipt at Setra for the repair and return of the unit. Non-warranty repairs will not be made without customer approval and a purchase order to cover repair charges.

Calibration Services

Setra maintains a complete calibration facility that is traceable to the National Institute of Standards & Technology (NIST). If you would like to recalibrate or recertify your Setra pressure transducers or transmitters, please call our Repair Department at 800-257-3872 (978-263-1400) for scheduling.

9.0 WARRANTY AND LIMITATION OF LIABILITY

SETRA warrants its products to be free from defects in materials and workmanship, subject to the following terms and conditions: Without charge, SETRA will repair or replace products found to be defective in material or workmanship within the warranty period; provided that:

- a) the product has not been subjected to abuse, neglect, accident, incorrect wiring not our own, improper installation or servicing, or use in violation of instructions furnished by SETRA;
- b) the product has not been repaired or altered by anyone except SETRA or its authorized service agencies;
- c) the serial number or date code has not been removed, defaced, or otherwise changed; and
- d) examination discloses, in the judgment of SETRA, the defect in materials or workmanship developed under normal installation, use and service;
- e) SETRA is notified in advance of and the product is returned to SETRA transportation prepaid.

Unless otherwise specified in a manual or warranty card, or agreed to in writing and signed by a SETRA officer, SETRA pressure and acceleration products shall be warranted for one year from date of sale.

The foregoing warranty is in lieu of all warranties, express, implied or statutory, including but not limited to, any implied warranty of merchantability for a particular purpose.

SETRA's liability for breach of warranty is limited to repair or replacement, or if the goods cannot be repaired or replaced, to a refund of the purchase price. SETRA's liability for all other breaches is limited to a refund of the purchase price. In no instance shall SETRA be liable for incidental or consequential damages arising from a breach of warranty, or from the use or installation of its products.











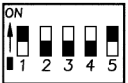

No representative or person is authorized to give any warranty other than as set out above or to assume for SETRA any other liability in connection with the sale of its products.

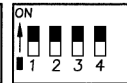
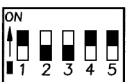
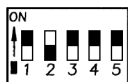
For all CE technical questions, contact Setra Systems, USA. EU customers may contact our EU representative Hengstler GmbH, Umlandstr. 49, 78554 Aldingen, Germany (Tel: +49-7424-890, Fax: +49-7424-89500).

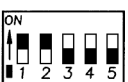
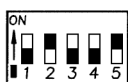
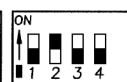
Table of Contents

1.0 GENERAL INFORMATION	1
2.0 MECHANICAL INSTALLATION	2
2.1 Media Compatibility	2
2.2 Environment	2
2.3 Pressure Fittings	2
3.0 ELECTRICAL INSTALLATION	2
3.1 Voltage Output Units 1/2" Conduit Opening, PG9, PG-13.5 Electrical Termination	2
3.2 Voltage Output Units 9 Pin D-sub Connector Electrical Termination	4
3.3 Current Output Units 1/2" Conduit Opening, PG9, PG-13.5 Electrical Termination	4
3.4 Current Output Units 9 Pin D-sub Connector Electrical Termination	5
3.5 4-20 mA Circuit Diagram	5
3.6 EMC Certification	5
4.0 CALIBRATION	6
4.1 Voltage Output Zero Adjustment	6
4.2 Voltage Output Span Adjustment	6
4.3 Current Output Zero Adjustment	7
4.4 Current Output Span Adjustment	7
5.0 MODEL 267 OPTIONAL LCD DISPLAY	7
6.0 MODEL 267MR MULTI-RANGE OPERATION	8
7.0 MODEL 267 & 267MR PERFORMANCE SPECIFICATIONS	9
8.0 RETURNING PRODUCTS FOR REPAIR	10
9.0 WARRANTY AND LIMITATION OF LIABILITY	10
10.0 MODEL 267 DESICCANT COVER	11
10.1 Regenerate the Desiccant	11
10.2 Replacing the Desiccating Cover	11

TABLE-2 RANGE SWITCHING INSTRUCTIONS FOR PASCAL RANGES

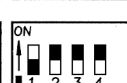
MR5 RANGE	MR6 RANGE	MR7 RANGE	MR8 RANGE	MR9 RANGE	SWITCH SETTINGS 0-5V OUTPUT	SWITCH SETTINGS 0-10V OUTPUT	SWITCH SETTINGS 4-20mA OUTPUT
Factory Default Setting							
0-25Pa	0-200Pa	0-1000Pa	0-2500Pa	0-7500Pa			
	0-100Pa	0-500Pa	0-1250Pa	0-3750Pa			
	0-50Pa	0-250Pa	0-625Pa	0-1875Pa			
±12.5Pa	±100Pa	±500Pa	±1250Pa	±3750Pa			
	±50Pa	±250Pa	±625Pa	±1875Pa			
	±25Pa	±125Pa	±312Pa	±937Pa			

7.0 MODEL 267 & 267MR PERFORMANCE SPECIFICATIONS

Accuracy RSS* (at constant temperature.)	±1.0% FS
Non-Linearity, BFSL	±0.98% FS
Hysteresis	0.2% FS
Non-Repeatability	0.1% FS
*RSS of Non-Linearity, Non-Repeatability and Hysteresis.	
<u>Thermal Effects</u>	
Compensated Range °F(°C)	+40 to +150 (+5 to +65)
Zero/Span Shift %FS/°F(°C)	0.033 (0.06)
Maximum Line Pressure	10 PSI
Overpressure	Up to 10 PSI (range dependent)
Warm-up Shift	±0.1% FS total
<u>Position Effects</u>	
(Unit is factory calibrated at 0g effect in the vertical position)	
Range	Zero Offset (%FS/G)
0 to 1" WC	2.1
0 to 1" WC	.22
0 to 5" WC	.14

6.0 MULTI-RANGE OPERATION - MODEL 267MR ONLY

The 267MR is re-rangeable by accessing the switches located internal to the transducer housing. To access the "Dip" switches, remove the screws on the top of the case and lift off the cover. The "Dip" switches are located on the electronics board as shown in Diagrams 1 and 5. The voltage output version has 5 switches. The current version has 4. The location of these switches, "on" (up position) or "off" (down position), determine what range has been selected. See Table 1 or 2 below for switch positions for in.WC or Pascals.

Multi-Range units are factory set to the highest range. As an example, an MR2 range is factory set to 0 to 1" W.C.

If it is a 0-5 VDC output, the switches are set:

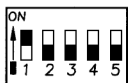

To change the range to 0 to .25" W.C. with a 0-10 VDC output, change the switches to:

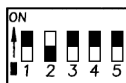

If the 267MR Range is re-configured from the factory calibration, place the correct range label (enclosed) on the cover label, over the area indicating the factory default range.

Notes: Voltage output is set based upon ordering code.
See switch settings below to confirm voltage output.
The 4-20 mA current version has only 4 switches.

TABLE-1 RANGE SWITCHING INSTRUCTIONS FOR IN.WC

MR1 RANGE	MR2 RANGE	MR3 RANGE	MR4 RANGE	SWITCH SETTINGS 0-5V OUTPUT	SWITCH SETTINGS 0-10V OUTPUT	SWITCH SETTINGS 4-20MA OUTPUT
Factory Default Setting						
0-0.1"	0-1"	0-5"	0-30"			
	0-.5"	0-2.5"	0-15"			
	0-.25"	0-1.25"	0-7.5"			
±0.05"	±.5"	±2.5"	±15"			
	±.25	±1.25"	±7.5"			
	±.125"	±.625"	±3.75"			

Setra Systems Model 267 and Model 267MR

1.0 GENERAL INFORMATION

Every Model 267 and Model 267MR (Multi-Range) has been tested and calibrated before shipment. Specific performance specifications are listed on Page 9 of this Guide.

The Model 267 is single range only. The Model 267MR has field selectable range capability. The 267MR is factory calibrated for the highest pressure range. The range label on the cover of the unit indicates the factory-calibrated range. Should the 267MR be re-ranged in the field, other Multi-Range labels are included.

Setra Systems 267 and 267MR pressure transducers sense differential or gauge (static) pressure and convert this pressure difference to a proportional high level analog output for both unidirectional and bidirectional pressure ranges. Two output versions are offered: A configurable voltage output of 0 to 5 VDC or 0 to 10 VDC, and a current output of 4 to 20 mA.

Sections 1 through 4 and 7 through 9 of this Guide apply to both Models 267 and 267MR. Section 5 refers to the Model 267 only. Section 6 refers to the Model 267MR only.

2.0 MECHANICAL INSTALLATION

2.1 Media Compatibility

Model 267 and 267MR transducers are designed to be used with air or nonconducting gases. Use with liquids or corrosive gases will damage the unit.

2.2 Environment

The operating temperature limits of the 267 and 267MR are as follows:

Operating Temperature	0°F to +150°F (-18°C to +65°C)
Compensated Temperature Range	+40°F to +150°F (+5°C to +65°C)

2.3 Pressure Fittings

The Model 267 and 267MR can be supplied with three different pressure fitting configurations:

- A. 3/16" O.D. Barbed Brass Pressure Fittings – Typically installed with 1/4" push-on tubing
- B. 1/4" NPT Brass Pressure Fittings – Typically installed with mating NPT male fitting.
- C. Static Pressure Probe – Installed on the duct by drilling a 7/16" hole in the duct at the desired mounting location, inserting the pressure probe into the duct, and mounting the 267 onto the duct with the mounting tabs.

For the 3/16" O.D. and 1/4" NPTF pressure fittings, both the positive (high) pressure port and the reference (low) pressure port are located on the bottom of the unit, labeled "HIGH" and "LOW" respectively. For best results (shortest response times), 3/16" I.D. tubing is suggested for tubing lengths up to 100 feet long, 1/4" I.D. for tubing lengths up to 300 feet, and 3/8" I.D. for tubing lengths up to 900 feet.

The static pressure probe is the positive (high) pressure port located on the back of the unit. The reference (low) pressure port is located on the bottom of the unit and can be used for differential pressure measurements.

3.0 ELECTRICAL INSTALLATION

Wiring is through a 1/2" conduit opening or factory installed PG-9, PG-13.5 or 9 pin D-sub connector. (See Section 3.2 for instructions on wiring the 9 pin D-sub connector.) Both current and voltage output units are reverse wiring protected.

3.1 Voltage Output Units - 1/2" Conduit Opening, PG9 or PG-13.5 Electrical Termination

Wiring terminations are identified on the circuit board below the terminal strip (see Section 3.1 for voltage output units or Section 3.3 for current units). To access the terminal strip, turn the screws on top of the case counter clockwise until the cover can be removed. The screws are captured and will be secured in the top of the case.

With full range pressure applied to the high pressure port (reference port open to atmosphere), the span may be adjusted by turning the SPAN adjustment screw. (See Diagram 1 for location of SPAN adjustment.) Factory settings are:

Unidirectional Pressure Ranges		Bidirectional Pressure Ranges	
Span Adjustment	Output	Span Adjustment	Output
5.0 VDC (± 25 mV)	0-5 VDC	2.5 VDC (± 25 mV)	0-5 VDC
10 VDC (± 50 mV)	0-10 VDC	5 VDC (± 50 mV)	0-10 VDC

Example 1: Unidirectional pressure range of 0 to 1" W.C. with 0 to 5 VDC output
Apply 1.00" W.C., adjust span to 5 VDC (\pm mv)

Example 2: Bidirectional pressure range of ± 5 " W.C. with 0 to 5VDC output
Apply 5.00" W.C., adjust span to 5 VDC (± 25 mV)

4.3 Current Output Zero Adjustment

While monitoring the current output, and with both pressure ports open to atmosphere, the zero may be adjusted by turning the zero adjustment screw. (See Diagram 3 for location of zero adjustment) Factory settings are:

Unidirectional Pressure Ranges		Bidirectional Pressure Ranges	
Zero Adjustment	Output	Zero Adjustment	Output
4mA (0.08 mA)	4-20 mA	12 mA (0.08 mA)	4-20 mA

4.4 Current Output Span Adjustment

Span or full scale output adjustments should only be performed by using an accurate pressure standard (electronic manometer, digital pressure gauge, etc.) with at least comparable accuracy to the 267 or 267MR transducer ($< \pm 1\%$ FS). With full range pressure applied to the high pressure port (reference port open to atmosphere), the span may be adjusted by turning the SPAN adjustment screw. (See Diagram 1 for location of SPAN adjustment.) Factory settings are:

Unidirectional Pressure Ranges		Bidirectional Pressure Ranges	
Span Adjustment	Output	Span Adjustment	Output
20mA (0.08 mA)	4-20 mA	20 mA (0.08 mA)	4-20 mA

Example 1: Unidirectional pressure range of 0 to 1" W.C. with 4 to 20 mA output
Apply 1.00" W.C., adjust span to 20 mA (± 0.08 mA)

Example 2: Bidirectional pressure range of 5" W.C. with 4 to 20 mA output
Apply 5.00" W.C., adjust span to 20 mA (± 0.08 mA)

5.0 MODEL 267 OPTIONAL LCD DISPLAY

The Model 267 is available with an optional 3 1/2 digit LCD display. The LCD display is adjusted at the factory prior to shipment. The LCD is connected to the zero and span adjustment potentiometers. Therefore, adjustment of the zero and span according to Section 4 adjusts the LCD display.

2. If unshielded cable is used, an earth grounded metal conduit fitting can be used to replace the shielded cable.
3. For a sensor with a metal body or enclosure, the body/enclosure must be grounded to earth. If a protective metal housing is used, the metal housing should be grounded to earth
4. If a protective plastic housing is used, the housing must be able to withstand at least 2 KV from the housing to earth ground, without damaging the circuit.
5. The unit shall be installed or operated in a controlled electromagnetic environment.

4.0. CALIBRATION

The 267 and 267MR transducer is factory calibrated and should require no field adjustment. Generally, the mounting position will have a zero shift effect on ranges below 1"WC. Whenever possible, any zero and/or span offsets should be corrected by software adjustment in the user's control system. However, both zero and span adjustments are accessible under the cover of the unit, below and to the right of the terminal strip. The 267 and 267MR transducer is calibrated in the vertical position at the factory (mounting tabs vertical).

4.1 Voltage Output Zero Adjustment

While monitoring the voltage between the positive output (+SIG) and common (GND), and with both pressure ports open to atmosphere, the zero may be adjusted by turning the zero adjustment screw. (See Diagram 1 for location of zero adjustment.) Factory settings are:

Unidirectional Pressure Ranges		Bidirectional Pressure Ranges	
Zero Adjustment	Output	Zero Adjustment	Output
0.05 VDC (± 25 mV)	0-5 VDC	2.5 VDC (± 25 mV)	0-5 VDC
0.05 VDC (± 50 mV)	0-10 VDC	5 VDC (± 50 mV)	0-10 VDC

4.2 Voltage Output Span Adjustment (Complete the zero adjustment before setting span.)

Span or full scale output adjustments should only be performed by using an accurate pressure standard (electronic manometer, digital pressure gauge, etc.), with at least comparable accuracy to the 267 or 267MR transducer ($\leq \pm 1\%$ FS).

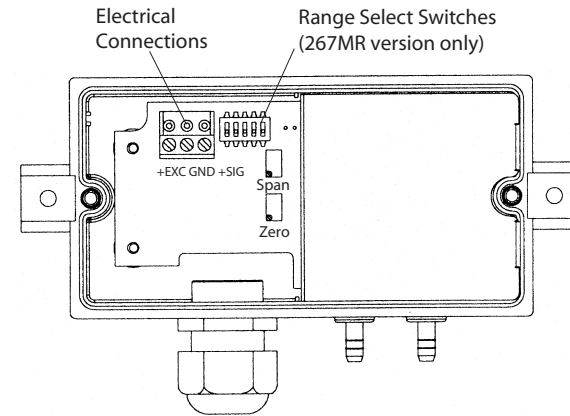

Diagram 1

The Model 267 and 267MR voltage output is a 3-wire circuit, with three terminals available for wiring (see Diagram 1). The -Excitation and -Output are commoned on the circuit (see Diagram 2). The excitation/output specifications are:

Excitation	Output
9 to 30 VAC / 11.5 to 42 VDC	0 to 5 VDC
12 to 30 VAC / 13 to 42 VDC	0 to 10 VDC

The 267MR has a field selectable 0 - 5 or 0 - 10 VDC output. (See Section 6.0 for switch settings to determine whether the voltage output is set to 0-5 or 0-10 VDC.) The 267 has either a 0-5 VDC or 0-10 VDC output, calibrated at the factory.

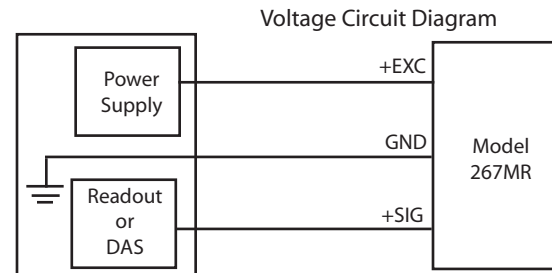
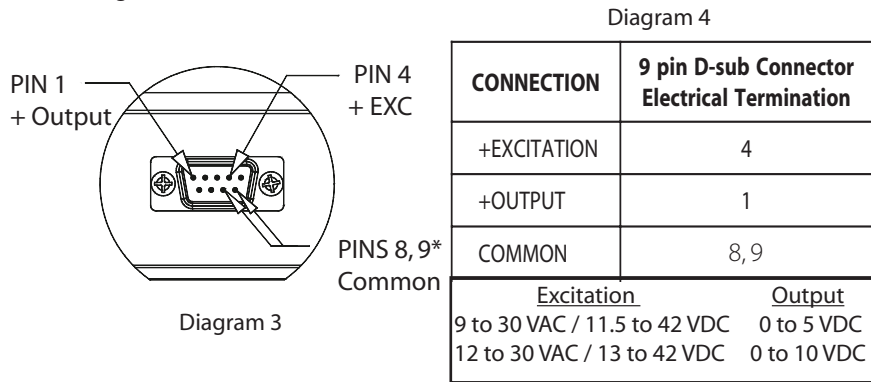

Diagram 2

- +EXC Connected to positive terminal of DC or AC power supply
- GND Connect as the reference for power supply and output signal
- +SIG Connect to positive terminal of control or pressure monitor

3.2 Voltage Output Units - 9 pin D-sub Connector Electrical Termination

The Model 267 and 267MR voltage output is a 3-wire circuit, with three pins available for wiring (see Diagram 3). The voltage output pin designations are shown in Diagram 4:



*Pins 8 and 9 are internally commoned together, user can connect to either pin.

3.3 Current Output Units - 1/2" Conduit Opening, PG9 or PG-13.5 Electrical Termination

The Model 267 and 267MR is a two-wire loop-powered 4 to 20mA current output unit (see Diagram 5). The current flows into +EXC. terminal and returns back to the power supply through the -EXC. terminal (see Diagram 6). The power supply must be a DC voltage source with a voltage range between 9 and 30 measured between terminal +EXC. and -EXC. The unit is calibrated with a 24VDC loop supply voltage and a 250 ohm load.

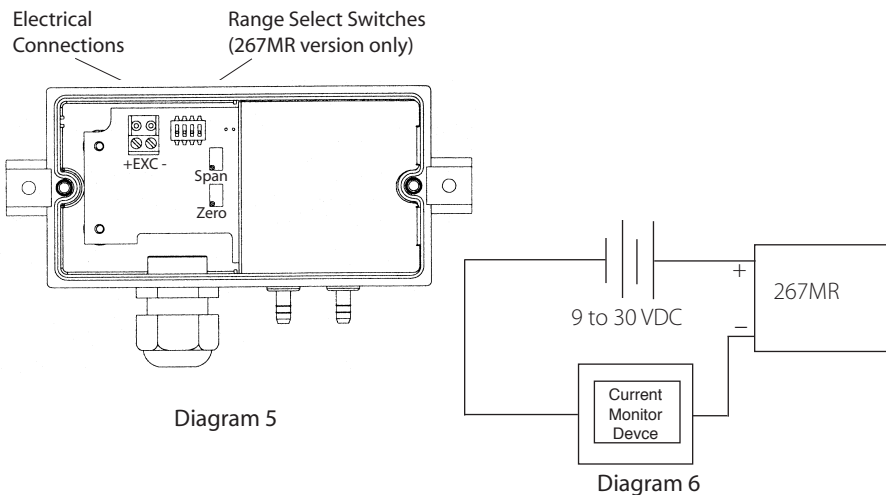

3.4 Current Output Units - 9 pin D-sub Connector Electrical Termination

The Model 267 and 267MR is a two-wire loop-powered 4 to 20mA current output unit (see Diagram 6). The current flows into +EXC. Pin 4 (+EXC) and returns back to the power supply through Pin 9 (-EXC) (see Diagram 7). The power supply must be a DC voltage source with a voltage range between 9 and 30 measured between Pin 4 and Pin 9 (-EXC). The unit is calibrated with a 24VDC loop supply voltage and a 250 ohm load. The current output 9 pin D-sub connector pin designations are shown in Diagram 8.

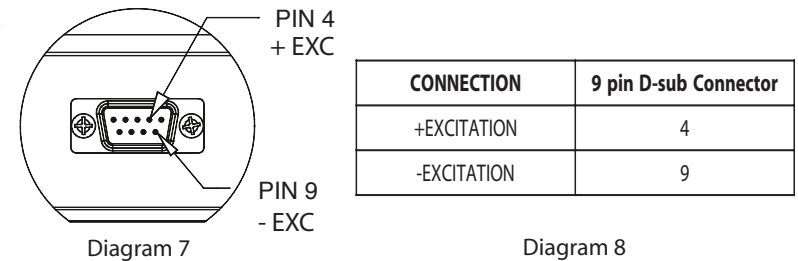

3.5 4-20 mA Circuit Diagram

Minimum Supply Voltage (VDC) = $9 + 0.02 \times (\text{resistance of receiver plus line})$
 Maximum Supply Voltage (VDC) = $30 + 0.004 \times (\text{resistance of receiver plus line})$.
 If the current loop has a current limiter, the threshold should be adjusted to 35 mA minimum (see Diagram 9).

Loop Power Supply vs. Loop Resistance for 4 to 20 mA Current Transducers

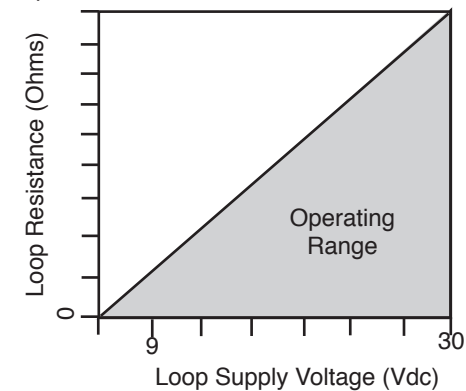

3.6 EMC Compliance

This product complies with EN61326-1:2006 in accordance with EN61326-2-3:2006 to be used in Controlled EM Immunity and Class B Emission environment. Special cautions must be taken to fully meet EU EMC compliance:

1. Shielded cable must be used, and the shield must be tied to earth ground (not power supply ground) on at least one end of the cable shield/drain wire. The shield must be maintained all the way from sensor to the power supply.